



## VOLVO CARS RECOMMENDED EQUIPMENT



**Attrezzatura  
consigliata**

(IT)

**Recommended  
equipment**

(EN)

**Empfohlene  
Werkstattausrüstung**

(DE)

**Équipement  
conseillé**

(FR)

**Equipos  
recomendados**

(ES)

## WHEEL ALIGNMENT - CCD CAMERAS

### ARC 78WS

8-CCD sensor wheel aligner.

Volvo specification number: **6.101.03**

**SPJ SE 25716**

Infra-red transmission among measuring heads. Bluetooth transmission between front measuring heads and control unit. Maximum mobility between different working positions thanks to the absence of cables and any fix structure.



#### STANDARD

- 1 control unit with PC, key-board, printer and battery-charger
- 2 front measuring heads
- 2 rear measuring heads
- 2 pair of four point clamps
- 1 pair of S110A7 turn tables
- 1 brake pedal depressor
- 1 steering wheel lock
- Instruction manual on CD

Recommended accessories:

**STDA72** (2 set)

24" to 28" extensions for 2 clamps

## WHEEL ALIGNMENT - 3D

### ARP 3DHP.B

3D wheel aligner.

Volvo specification number: **6.101.03**

**SPJ SE 25716**

Premium cabinet 3-point clamps



Quick battery change.



Keyboard with remote-control function.

Recommended accessories:

**STDA72** (2 set) - 24" to 28" extensions for 2 clamps

### ARP 3DS.B

3D wheel aligner.

Volvo specification number: **6.101.03**

**SPJ SE 25716**

Space saver cabinet 4-point clamps



Can be used on any 4 post or scissors lift.  
Automatic lift level compensation.



2 universal supports included



# SCISSOR LIFTS

## Lifts with flat platforms

- SF 6351 / 3500 kg
- SF 6401 / 4200 kg
- SF 6501 / 5000 kg
- SF 6601 / 6000 kg

Volvo specification number: **0.105.03**  
**SPJ 25662**

## Wheel alignment lifts

- SF 6352 / 3500 kg
- SF 6402 / 4200 kg
- SF 6502 / 5000 kg
- SF 6602 / 6000 kg

Volvo specification number: **0.105.03**  
**SPJ 25662**

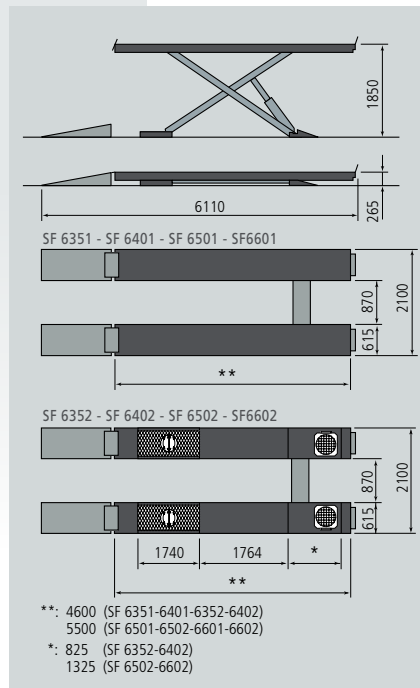

## Jacking Beam

- J20PNX / 2000 kg air-hydraulic
- J20PNXL / 2000 kg air-hydraulic large
- J30PRL / 3000 kg air-hydraulic large

Volvo specification number: **0.103.03**

Air-hydraulic scissor wheel-free jack

## Low Profile Scissor Lifts

- SFL 5518 / 3000 kg (H min = 110 mm)
- SFL 5518T / 3000 kg (H min = 95 mm)
- SFL 5535 / 3500 kg (H min = 100 mm)

Volvo specification number **0.105.03**  
**SPJ 25661**

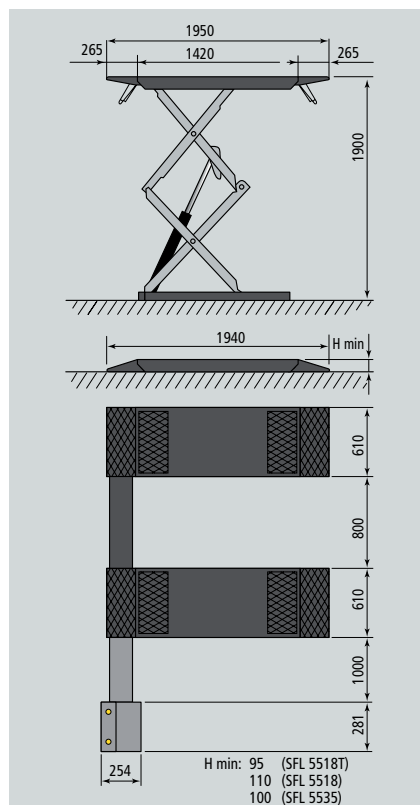



## BRAKE TESTER

### PFC 750 E000

Computerised control unit  
with colour TFT monitor 17".

Volvo specification number: **5.101.04**

**SPJ SE 25715**

### PFB 040 0000

Roller brake tester

Motors: 4,7 + 4,7 kW

Breaking measurement up to **6000N**

Available also with selfbraking motors  
and built-in weighting unit.

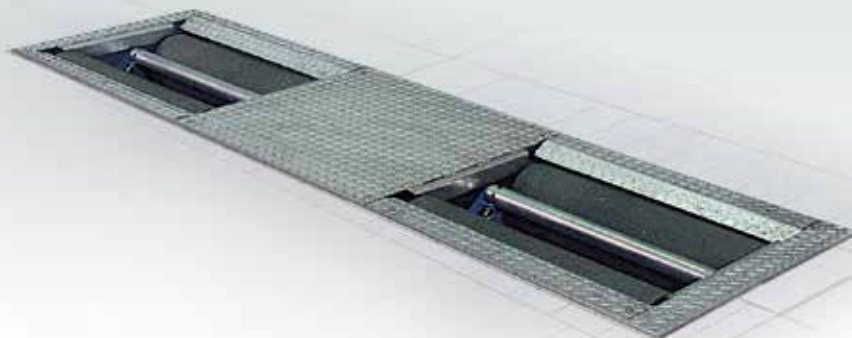

## WHEEL BALANCERS

### ER 255RS

Computerised control unit  
with colour TFT monitor 17".

Volvo specification number: **5.101.04**

**SPJ 25717**



### ER 238H

A low rotation speed balancer. Entry level model  
of the motorised range, the machine offers great  
value for money and occupies a very limited  
space, it also gives professional performances.  
Guided ALU S programme. Guided rim/tyre  
optimisation.

Volvo specification number: **7.101.04**

**SPJ 25717**



WHEEL WIDTH GAUGE



DOUBLE LED LIGHT



LASER POINTER



**Recommended accessories:**  
**GAR131H - Universal flange**

## TYRE CHANGERS



### GA 2645.26

Automatic tyre changer with tilting column.  
 External self-centering lock: 10"-26"  
 Internal self-centering lock: 12"-28"  
 Maximum tyre width: 17"  
 Volvo specification number: **7.102.02**  
**SPJ SE 25718**



### Recommended accessories:

- G800A6** - 4 clamp protections
- G800A8** - Tool protection
- G800A11** - Bead breaker protection

### GA 2645V.26 + PLUS83N

Automatic tyre changer with:

- tilting column
- a large and reinforced frame
- with 2 speed motor
- inflation device

External self-centering lock: 10"-26"  
 Internal self-centering lock: 12"-28"  
 Maximum tyre width: 17"  
**PLUS83N** - Helping arm  
 Volvo specification number: **7.102.03**  
**SPJ SE 25718**

### EASY DEMOUNTING



### EASY MOUNTING



### SYNCR O ROLLERS



### GA 560.30 IT

Leverless tyre changer with:

- center locking
- plastic tool
- variable speed motor
- inflation device
- Max rim diameter: 10"-30"

Maximum tyre width: 15"  
**PLUS96** - Helping arm  
**G1000A112** - Wheel lift  
 Volvo specification number: **7.102.04**  
**SPJ SE 25718**

The bead-breaking is performed by means of an **EASY ROLLER**:

- bead-breaking in correct position
- easy rotation of the roller
- automatic side-movement of the roller
- memorized position for bead breaking of wheel lower side



## IN GROUND PISTON LIFTS

### SDI 110NK / 3500 kg

Version with lifting arms

**S1110A5** - Complete waterproof frame

Volvo specification number: **11.110.01**

**SPJ SE 26125**

### SDI 120M / 3500 kg

Lift with adjustable track of pick up supports

**S1110A5** - Complete waterproof frame

Volvo specification number: **11.110.01**

**SPJ SE 26125**

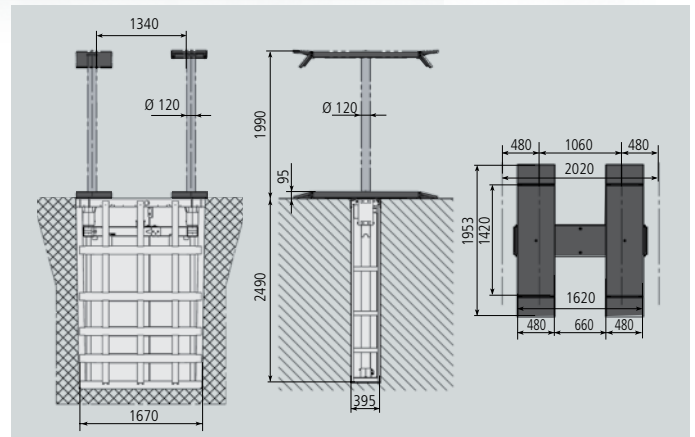
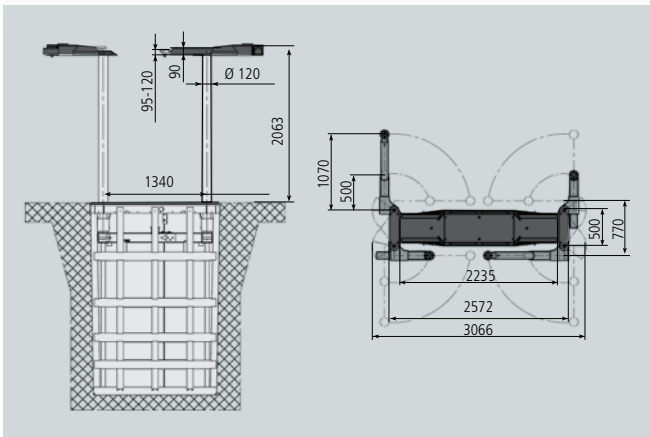
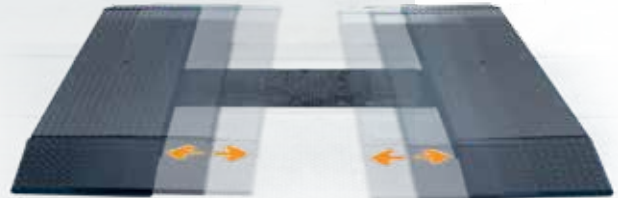

## 4 POST LIFTS - OPEN FRONT

### Lifts with flat platforms

**SQ 505 OFSI** / 5000 kg

Volvo specification number: **0.103.03**

**SPJ SE 25660**

### Wheel alignment lifts

**SF 506 OFSI** / 5000 kg

Volvo specification number: **0.103.03**

**SPJ SE 25660**



**SQ 505 OFSI**

**SF 506 OFSI**

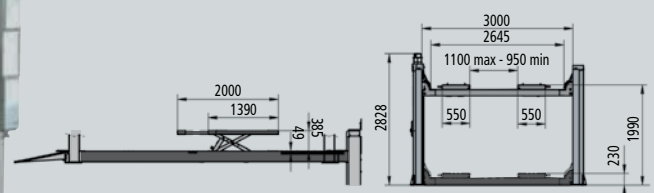
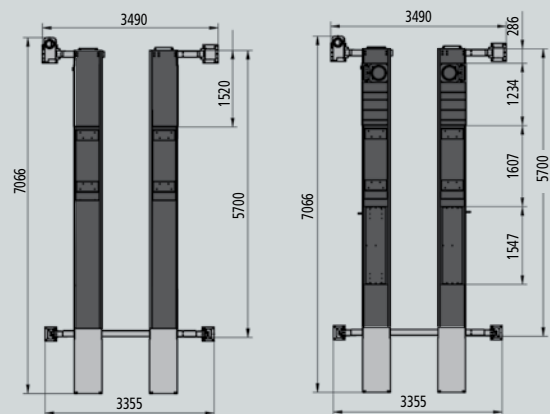

## 4 POST LIFTS

### Versions with flat platforms

**SQ 401** / 4000 kg  
**SQ 405E** / 4000 kg  
**SQ 501E** / 5000 kg

Volvo specification number: **0.103.03**

**SPJ SE 25660**

Technical Data		SQ 401	SQ 405E	SQ 501E
Capacity	kg	4000	4000	5000
Motor	kW	2,6		
Dimensions				
A		500	530	
C max		1250		1180
C min		910	860	786
D		2470	2670	2645
E	mm	2800	3000	
F		3365	3355	
H max		1905	1915	
H min		150	160	
L		4460	5100	5700
M		5190	6170	6670

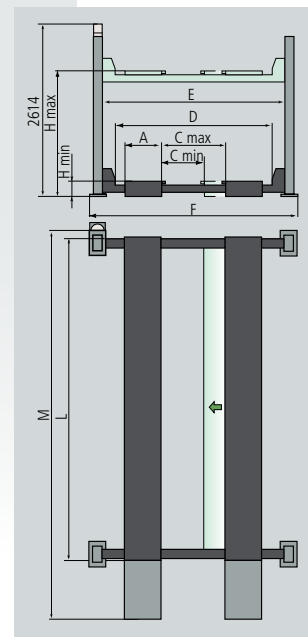

### Versions for full wheel alignment

**SQ 402** / 4000 kg  
**SQ 406E** / 4000 kg

Platforms for total wheel alignment with front turning plates locations and rear slip plates.

**SQ 502E** / 5000 kg

Extra-long platforms for total wheel alignment with front turning plates locations and rear slip plates.

Volvo specification number: **0.103.03**

**SPJ SE 25660**

Technical Data		SQ 402	SQ 406E	SQ 502E
Capacity	kg	4000	4000	5000
Motor	kW	2,6		
Dimensions				
A			530	
C max		1210	1225	1180
C min		860	853	786
D		2470	2670	2645
E	mm	2800	3000	
F		3365	3355	
H max		1915	1915	
H min		160	210	
L		4460	5100	5700
M		5190	6318	6913

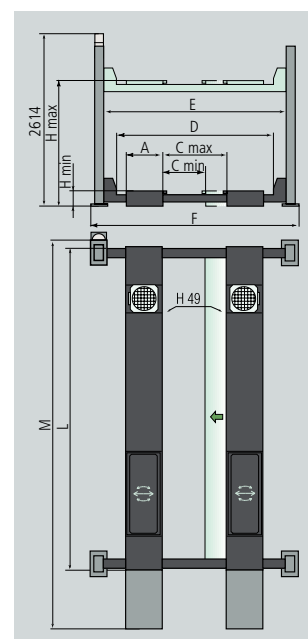

## 2 POST LIFTS

### Electromechanical baseless 2-post lift

**SDE 2337K** / 3200 kg  
 Volvo specification number:  
**11.108.01**  
**SPJ SE 26123**

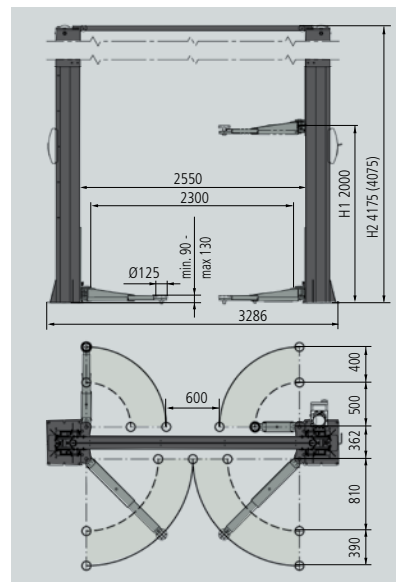
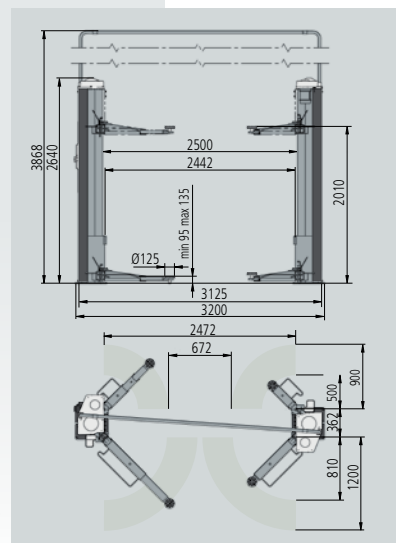

### Electrohydraulic baseless 2-post lift

**SDH 370.32K** / 3200 kg  
 Volvo specification number: **11.108.01**  
**SPJ SE 26123**

**SDH 370.42K** / 4200 kg  
 Volvo specification number: **11.108.01**  
**SPJ SE 26123**

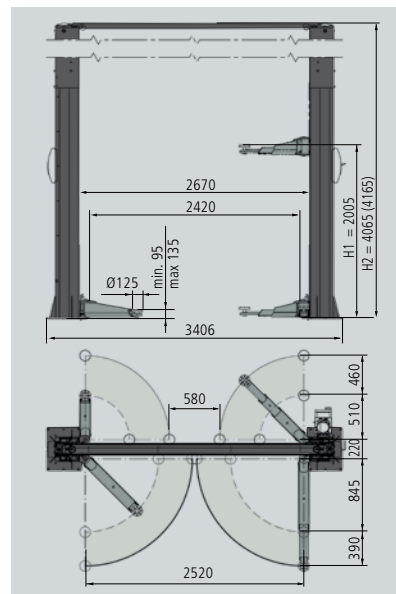

### SPACE s.r.l. a s.u.

Via Sangano, 48  
 10090 Trana - Torino - ITALY  
 tel. +39-011-934.40.300  
 fax +39-011-933.88.64  
 e-mail: info@spacetest.com  
 www.spacetest.com